

Filing Category: DESIGN—Wood

PACIFIC WOODTECH CORPORATION PWI JOISTS

PACIFIC WOODTECH CORPORATION
1850 PARK LANE
BURLINGTON, WASHINGTON 98233

CAPITAL LUMBER COMPANY
2111 EAST HIGHLAND AVENUE, SUITE 155
PHOENIX, ARIZONA 85016

FRANKLIN BUILDING SUPPLY COMPANY
11700 FRANKLIN ROAD
BOISE, IDAHO 83709

GEORGIA-PACIFIC CORPORATION
4300 WILDWOOD PARKWAY
ATLANTA, GEORGIA 30339

ROSEBURG FOREST PRODUCTS COMPANY
4500 RIDDLE BY-PASS ROAD
RIDDLE, OREGON 97469

INTERNATIONAL PAPER COMPANY /
ENGINEERED WOOD PRODUCTS DIVISION
206, 2723 – 37TH AVENUE N.E.
CALGARY, ALBERTA T1Y 5R8
CANADA

1.0 SUBJECT

Pacific Woodtech Corporation (PWC) private label I-joists: Franklin FBI, Georgia-Pacific Wood I Beam®, Roseburg RFPI™, Capital CCI, and Weldwood™ I-joists.

2.0 DESCRIPTION

2.1 General:

Pacific Woodtech Corporation (PWC) manufactures private-label I-joists. Private labels include, but are not limited to, Franklin FBI, Georgia-Pacific Wood I Beam®, Roseburg RFPI™, Capital CCI, and Weldwood™ I-joists. All I-joists are identified by the designation "PWC" and the evaluation report number (PFC-5804). The PWI joists described in this report are prefabricated wood I-joists that comply with Section 2303, Item 5.1, in the 1997 *Uniform Building Code*™ (UBC), Section 2303.1.2 of the 2000 *International Building Code*® (IBC) and Section R502.1.4 of the 2000 *International Residential Code*® (IRC), for allowable stress design; Section 2313.5 of the BOCA® *National Building Code*/1999; and Section 2301.4.11 of the 1999 *Standard Building Code*®.

PWI joists are manufactured to meet the performance standard recognized in PFC-5317 (PRI-400, *Performance Standard for APA EWS I-joists*), and/or the Pacific Woodtech Corporation *I-Joist Quality Control Manual*. The PWI joists consist of laminated veneer lumber (LVL) or machine stress rated (MSR) lumber flanges and oriented strand board (OSB) webs.

Flange stock used to fabricate the PWI joists is LVL (Douglas fir) or MSR (spruce-pine-fir) lumber of the grade required by the Pacific Woodtech Corporation quality control manual.

Webs are structural use panels that comply with evaluation report ER-5681 and the approved quality control manual. The web sections are made up of minimum 8-foot-long (2438 mm) elements that are edge-glued to form a continuous web using a tongue-and-groove joint. The web-to-flange glued connection is made by inserting the web into a groove in the center of the flange face.

Exterior-type adhesives, complying with ASTM D 2559, are used for flange-flange, flange-web and web-web joints.

Descriptive details for the joists are noted in Table 1.

2.2 Installation:

2.2.1 Web Stiffeners: Web stiffeners are not required, with the following exceptions: (1) Web stiffeners are required at the ends of the I-joist in joist hangers that are not deep enough to laterally support the top flange of the joist. Refer to the hanger installation instructions. (2) Web stiffeners are required to accommodate special hanger nailing requirements. Refer to the hanger installation instructions. (3) Web stiffeners are required under concentrated loads applied to the top of the I-joist between supports, or along cantilevers beyond the support, when the concentrated load exceeds 1500 pounds (6672 N). (4) Web stiffeners are required at birdsmouth cuts at the low end support of sloped joists. (5) Web stiffeners are required for high reactions at supports. See Table 2. See Figure 1 for illustrations as well as web stiffener dimensions and nail sizes.

2.2.2 Lateral Support: The compression flange must be laterally supported in accordance with the applicable code, and beam-ends must be restrained to prevent rotation. Diaphragm sheathing must be attached to the top flange and to an end wall or shear-transfer panel capable of transferring a minimum force of 50 pounds per foot (730 N/m).

2.2.3 Web Holes: Tables 4 and 5 provide allowable locations for round, rectangular and duct holes in joists sized by means of Table 3. For engineered designs, refer to *Tables 4 & 5 Notes* and use the following allowable hole shear values:

*Revised April 2003

ES REPORTS™ are not to be construed as representing aesthetics or any other attributes not specifically addressed, nor are they to be construed as an endorsement of the subject of the report or a recommendation for its use. There is no warranty by ICBO Evaluation Service, Inc., express or implied, as to any finding or other matter in this report, or as to any product covered by the report.



$$\text{Round holes: } V_{\text{hole}} = \frac{d - \text{Hole Diameter (inches)}}{d} \times V_{\text{joist}}$$

where:

V_{hole} = allowable joist shear at web hole [lbs].

d = joist depth [inches].

V_{joist} = allowable joist shear [lbs].

Rectangular holes: Substitute the longest side dimension divided by 0.75 for *Hole Diameter* in the round hole equation.

Duct holes (full height of web removed):

Series 20/30 $V_{\text{hole}} = 300 - 8.5 \times \text{Width}$

Series 50 $V_{\text{hole}} = 360 - 11 \times \text{Width}$

Series 40/60/70/77 $V_{\text{hole}} = 430 - 11.5 \times \text{Width}$

Series 80/90/93 $V_{\text{hole}} = 515 - 12 \times \text{Width}$

where:

V_{hole} = allowable joist shear at web hole [lbs].

Width = duct hole width [inches].

2.2.4 Other: Installation and construction details not specifically covered herein must be in accordance with evaluation report PFC-5317.

2.3 Design:

Allowable design properties are noted in Table 2. The tabulated moment capacity may be increased by a repetitive member factor of 1.04 for LVL flanges or 1.07 for MSR lumber flanges when joists or rafters are in contact or spaced not more than 24 inches (610 mm) on center, are not less than three in number and are joined by floor or roof sheathing, or other load distributing elements adequate to support the design load. Moment and shear capacity are permitted to be increased for duration of load in accordance with the applicable code.

2.4 One-hour Fire-resistive Construction for Roof-ceiling and Floor-ceiling Assemblies:

2.4.1 Assembly 1: The I-joists described in this evaluation report, with minimum flange size of 1½ inches (38 mm) by 2½ inches (63.5 mm), can be used with the assembly described in Figure 7 of PFC-5317.

2.4.2 Assembly 2: I-joists can be used in the construction of the assembly described in Table 7-C, Item 21-1.1, of the UBC; or Table 719.1(3), Item 21-1.1, of the IBC. Minimum 9½-inch-deep (241 mm) wood I-joists must be spaced a maximum of 24 inches (610 mm) on center. Minimum flange size is 1⅝ inches thick by 1½ inches wide (33 mm by 38 mm). Minimum web thickness is ⅜ inches (9.5 mm).

2.4.3 Assembly 3: The I-joists described in this evaluation report can be used with the assembly details described in Section 2.3.3 of PFC-5317.

2.4.4 Assembly 4:

Finish flooring (optional)—Hardwood or softwood flooring on building paper; or resilient flooring, parquet floor, felt-synthetic-fiber floor coverings, carpeting, or ceramic tile on ⅜-inch-thick (9.5 mm) panel-type underlay; or ceramic tile on 1¼ inch (32 mm) mortar bed.

Subfloor—Wood structural panel sheathing in compliance with the provisions of PS1 or PS2 and the applicable building code.

Wood structural members—Minimum 9½-inch-deep (241 mm) wood I-joists spaced a maximum of 24 inches (610 mm) on center. Minimum flange size is 1½ inches thick by 1½ inches wide (38 mm by 38 mm). Minimum web thickness is ⅜ inches (9.5 mm).

Insulation (optional)—3½-inch (89 mm) glass fiber batts, or 3½-inch (89 mm) mineral wool batts.

Resilient channels—Minimum 0.018-inch-thick (0.46 mm) resilient channels are installed in continuous rows at a maximum spacing of 24 inches (610 mm) on center and are perpendicular to the joists. Attached to the bottom of each joist with a 1¼-inch-long (32 mm) screw. Additional channels may be installed between continuous rows at the locations of end joints in the first layer of ceiling. Extend the additional channel a minimum of 2 inches (51 mm) beyond the joists adjacent to each side of the gypsum board panels in the first layer of ceiling.

Ceiling—Two layers of ½-inch-thick (12.7 mm), Type X gypsum board in compliance with ASTM C 36. Long edge of both layers must be perpendicular to the channels (parallel to the joists). End and side joints must be staggered at least 16 inches (406 mm) from layer to layer. The first layer is fastened to the resilient channels with 1¼-inch (32 mm), Type S screws at 12 inches (305 mm) on center. Screws must be installed a minimum of ⅜ inch (9.5 mm) from end joints and a minimum of 1½ inches (38 mm) from side joints. The second layer must be fastened to the resilient channels with 1⅝-inch (41 mm), Type S screws at 12 inches (305 mm) on center. Screws must be installed a minimum of ½ inch (12.7 mm) from end and side joints. 1½-inch (38 mm), Type G screws may be substituted at end joints in the second layer when end joints fall between channels.

2.5 Identification:

Each I-joist shall be marked with the product trade name or trademark, the joist series, the production date, the evaluation report number (PFC-5804), the name or trademark of the quality assurance agency (APA-EWS), the manufacturer (PWC) and the manufacturer's APA mill number (1048).

3.0 EVIDENCE SUBMITTED

Product description; structural design calculations; in-plant quality control manual; results of full-scale tests and data showing compliance with the ICBO ES Acceptance Criteria for Prefabricated Wood I-joists (AC14), dated July 2000, and the APA Product Standard PRI-400, Performance Standard for APA EWS I-joists; and copies of PRI-400 and the APA Quality Assurance Policy.

4.0 FINDINGS

That the Pacific Woodtech PWI joists described in this report comply with the 1997 Uniform Building Code™, the 2000 International Building Code®, the 2000 International Residential Code®, the BOCA® National Building Code/1999 and the 1999 Standard Building Code®, subject to the following conditions:

4.1 I-joists are manufactured at the Pacific Woodtech facility in Burlington, Washington, with quality control inspections by APA-EWS (AA-649-1).

4.2 Allowable residential floor spans are in accordance with Table 3.

4.3 Design calculations and details for specific applications are furnished to the code official upon request, verifying compliance with this report and the applicable code.

4.4 I-joists are permitted in dry-use service conditions only.

4.5 Cutting of flanges is not permitted.

This report is subject to re-examination in one year.

Table 1 – Joist Descriptions

Joist Series	Joist Depths [in]		Flange Width [in]	Depth [in]	Web Thickness [in]	
	Minimum	Maximum			Material	Thickness
PR1-400 ⁽¹⁾	PWC ⁽²⁾					
PR1-20	PWI-20	11-7/8	1 3/4	1 3/8	OSB	3/8
PR1-30	PWI-30	11-7/8	1 1/2	1 1/2	OSB	3/8
PR1-40	PWI-40	16	2 5/16	1 3/8	OSB	3/8
PR1-40	PWI-40	16	2 1/2	1 3/8	OSB	3/8
PR1-40	PWI-40	16	2 1/2	1 1/2	OSB	3/8
PR1-50	PWI-50	16	1 3/4	1 1/2	OSB	3/8
PR1-60	PWI-60	16	2 5/16	1 3/8	OSB	3/8
PR1-60	PWI-60	16	2 1/2	1 3/8	OSB	3/8
PR1-60	PWI-60	16	2 1/2	1 1/2	OSB	3/8
-	PWI-70	20	2 5/16	1 1/2	OSB	3/8
-	PWI-93	16	3 1/2	1 1/2	OSB	3/8
-	PWI-77	20	2 5/16	1 1/2	OSB	7/16
-	PWI-90	24	3 1/2	1 1/2	OSB	7/16

For **SI**: 1 inch = 25.4 mm.

1. PR1-400 Performance Standard for APA EWS I-Joists (PFC-5317)
2. Pacific Woodtech Corporation

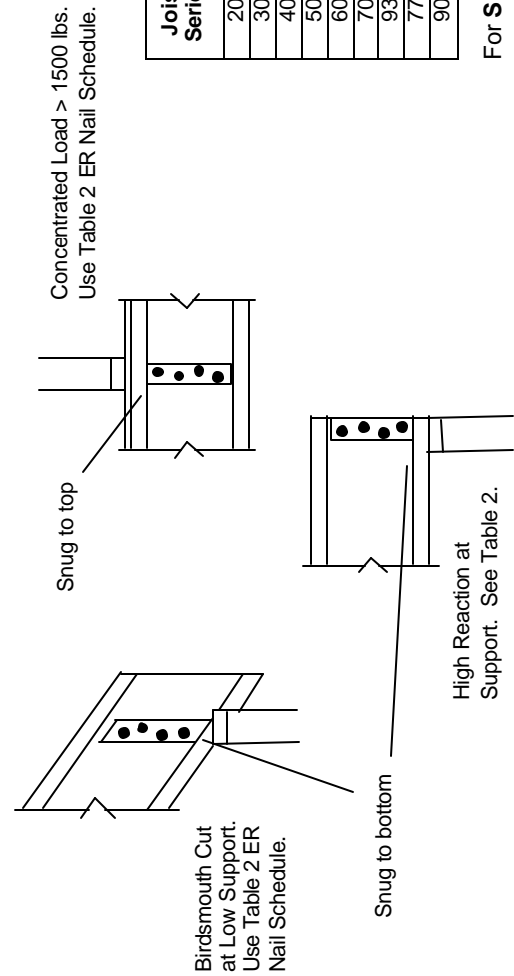

For **SI**: 1 inch = 25.4 mm.

Figure 1

Table 2 – Design Properties ⁽¹⁾

Joist Series	Joist Depth	EI [x 10 ⁶ lb-in ²]	k ⁽⁵⁾ [x 10 ⁶ lbs]	M ⁽⁶⁾ [ft-lbs]		V ⁽⁷⁾ [lbs]	ER ⁽⁸⁾ [lbs]			IR ⁽⁹⁾ [lbs]			WS ⁽¹⁰⁾ Nails	
				LVL	MSR		No WS	WS	No WS	WS	No WS	WS		
PRI-20	9-1/2" 11-7/8"	145 253	4.94 6.18	2180 2910	- -	1120 1420	830 830	N.A. N.A.	1056 1289	N.A. N.A.	1700 1700	N.A. N.A.	N.A. N.A.	4 4
PRI-30	9-1/2" 11-7/8"	161 280	4.94 6.18	2800 3715	- -	1120 1420	945 945	N.A. N.A.	1081 1314	N.A. N.A.	1905 1905	N.A. N.A.	N.A. N.A.	4 4
PRI-40	9-1/2" 11-7/8" 14" 16"	193 330 482 657	4.94 6.18 7.28 8.32	2423 3236 3971 4666	2355 3145 3860 4535	1120 1420 1710 1970	1080 1200 1200 1200	N.A. N.A. N.A. N.A.	1111 1371 1472 1472	N.A. N.A. N.A. N.A.	2160 2500 2500 2500	N.A. N.A. N.A. N.A.	N.A. N.A. N.A. N.A.	4 4 4 4
PRI-50	9-1/2" 11-7/8" 14" 16"	186 322 480 663	4.94 6.18 7.28 8.32	3290 4375 5350 6270	- - - -	1120 1420 1710 1970	1015 1015 1015 1015	N.A. N.A. N.A. N.A.	1097 1330 1303 1303	N.A. N.A. N.A. N.A.	2040 2040 2040 2040	N.A. N.A. N.A. N.A.	N.A. N.A. N.A. N.A.	4 4 4 4
PRI-60	9-1/2" 11-7/8" 14" 16"	231 396 584 799	4.94 6.18 7.28 8.32	3339 4460 5473 6430	3245 4335 5320 6250	1120 1420 1710 1970	1080 1200 1200 1200	N.A. N.A. N.A. N.A.	1111 1371 1472 1472	N.A. N.A. N.A. N.A.	2160 2500 2500 2500	N.A. N.A. N.A. N.A.	N.A. N.A. N.A. N.A.	4 4 4 4
-	11-7/8" 14" 16" 18" 20"	440 644 873 1141 1447	6.19 7.33 8.42 9.53 10.63	5945 7295 8570 9850 11135	- - - - -	1420 1710 1970 2239 2506	1160 1160 1160 1160 1160	1420 1592 1592 1808 1808	1420 1615 1615 1615 1615	N.A. 1710 1970 2239 2263	2840 2870 2870 3199 3199	N.A. N.A. N.A. N.A. N.A.	N.A. 3302 3302 3734 3734	4 4 4 8 8
-	11-7/8" 14" 16"	659 961 1301	6.18 7.28 8.32	8580 10530 12360	- - -	1420 1710 1970	1280 1280 1280	N.A. N.A. N.A.	1389 1490 1490	N.A. 1614 1817	2760 3020 3020	N.A. N.A. N.A.	N.A. N.A. N.A.	4 4 4
-	9-1/2" 11-7/8" 14" 16" 18" 20"	261 442 648 881 1152 1463	5.57 6.92 8.17 9.35 10.55 11.76	4450 5945 7295 8570 9850 11135	- - - - -	1675 1925 2125 2330 2535 2740	1390 1390 1390 1390 1390 1390	1675 1890 1890 1890 2140 2140	1675 1885 1885 1885 1885 1885	N.A. 1925 2125 2330 2535 2635	2780 2780 2780 2780 2780 2780	N.A. 3280 3280 3280 3280 3280	N.A. 3850 3895 3895 3895 4395 4395	4 4 4 4 8 8
-	9-1/2" 11-7/8" 14" 16" 18" 20" 22" 24"	392 661 965 1306 1703 2155 2664 3232	5.57 6.92 8.17 9.35 10.55 11.76 14.18	6800 9095 11165 13120 15085 17055 19025 20995	- - - - - - -	1675 1925 2125 2330 2535 2740 2935 3060	1400 1400 1400 1400 1400 1400 N.A. N.A.	1675 1900 1900 1900 2150 2150 2400 2400	1675 1900 1900 1900 1900 1900 N.A. N.A.	N.A. 1925 2125 2330 2535 2650 2900 2900	3350 3355 3355 3355 3355 3355 N.A. N.A.	N.A. 3850 3970 3970 3970 3970 3970 4605 4605	N.A. N.A. 4250 4470 4970 4970 5220 5220	4 4 4 4 8 8 10 10

For SI: 1 inch = 25.4 mm, 1 ft-lb = 1.35 N-m, 1 lb-in² = 179 N-mm², 1 lb = 4.45 N

Table 2 - Notes

1. The tabulated values are design values for normal duration of load. All values, except for EI and k, shall be permitted to be adjusted for other load duration as permitted by the code.
2. PRI-400 Performance Standard for APA EWS I-Joists
3. Pacific Woodtech Corporation
4. Bending stiffness (EI) of the I-joist.
5. Coefficient of shear deflection (k). For calculating uniform load and center point load deflections of an Ijoist in a simple-span application, use Equations 1 and 2.

$$\text{Uniform Load:} \quad d = \frac{5w^4}{384EI} + \frac{w^2}{k} \quad (1)$$

$$\text{Center Point Load:} \quad d = \frac{Pl^3}{48EI} + \frac{2Pl}{k} \quad (2)$$

Where:

d = calculated deflection (in)

w = uniform load (lbs/in)

l = design span (in)

P = concentrated load (lbs)

EI = bending stiffness of the I-joist (lbs-in²)

k = coefficient of shear deflection (lbs)

6. Moment capacity (M) of the I-joist. For repetitive Ijoists, the tabulated values may be increased by a factor of 1.04 for LVL flanges or 1.07 for MSR lumber flanges.
7. Shear capacity (V) of the I-joist.
8. End reaction capacity (ER) of the I-joist, for 1-1/2" and 3-1/2" bearing lengths, with (WS) and without web stiffeners (No WS).
9. Intermediate reaction capacity (IR) of the I-joist, for 3-1/2" and 5-1/4" bearing lengths, with (WS) and without web stiffeners (No WS).
10. Refer to Figure 1 for minimum nail dimensions.

Table 3 – Allowable Residential Floor Joist Spans⁽¹⁾⁽²⁾⁽³⁾⁽⁴⁾

Joist Series		Joist Depth	Simple Span				Continuous Span (two or more spans)			
PRI-400 ⁽⁵⁾	PWC ⁽⁶⁾		12" o.c.	16" o.c.	19.2" o.c.	24" o.c.	12" o.c.	16" o.c.	19.2" o.c.	24" o.c.
PRI-20	PWI-20	9-1/2"	16'-7"	15'-2"	14'-4"	13'-4"	18'-1"	16'-3"	14'-10"	13'-3"
		11-7/8"	19'-10"	18'-2"	17'-2"	15'-5"	21'-8"	18'-10"	16'-9"	13'-5"
PRI-30	PWI-30	9-1/2"	17'-1"	15'-8"	14'-10"	13'-10"	18'-7"	17'-0"	16'-1"	15'-0"
		11-7/8"	20'-6"	18'-9"	17'-8"	16'-6"	22'-4"	20'-5"	18'-10"	15'-0"
PRI-40	PWI-40	9-1/2"	18'-0"	16'-5"	15'-6"	14'-1"	19'-7"	17'-2"	15'-8"	14'-0"
		11-7/8"	21'-5"	19'-7"	18'-2"	16'-3"	23'-0"	19'-11"	18'-2"	16'-2"
		14"	24'-4"	22'-1"	20'-2"	18'-0"	25'-6"	22'-1"	20'-1"	18'-0"
		16"	26'-11"	24'-0"	21'-11"	19'-7"	27'-8"	23'-11"	21'-10"	19'-6"
PRI-50	PWI-50	9-1/2"	17'-10"	16'-4"	15'-5"	14'-5"	19'-5"	17'-9"	16'-9"	15'-7"
		11-7/8"	21'-4"	19'-6"	18'-5"	17'-2"	23'-3"	21'-2"	20'-0"	16'-1"
		14"	24'-4"	22'-2"	21'-0"	19'-7"	26'-6"	24'-2"	20'-2"	16'-1"
		16"	27'-0"	24'-8"	23'-4"	20'-2"	29'-6"	24'-3"	20'-2"	16'-1"
PRI-60	PWI-60	9-1/2"	18'-11"	17'-4"	16'-4"	15'-3"	20'-8"	18'-10"	17'-9"	16'-5"
		11-7/8"	22'-7"	20'-8"	19'-6"	18'-2"	24'-8"	22'-6"	21'-2"	19'-1"
		14"	25'-9"	23'-6"	22'-2"	20'-8"	28'-0"	25'-7"	23'-8"	19'-9"
		16"	28'-6"	26'-0"	24'-7"	22'-10"	31'-1"	28'-1"	24'-9"	19'-9"
-	PWI-70	11-7/8"	23'-4"	21'-3"	20'-1"	18'-8"	25'-5"	23'-2"	21'-10"	18'-6"
		14"	26'-6"	24'-2"	22'-9"	21'-2"	28'-10"	26'-3"	23'-2"	18'-6"
		16"	29'-3"	26'-8"	25'-2"	23'-1"	31'-11"	27'-10"	23'-2"	18'-6"
-	PWI-93	11-7/8"	26'-4"	23'-11"	22'-6"	20'-11"	28'-8"	26'-0"	24'-6"	21'-10"
		14"	29'-10"	27'-2"	25'-7"	23'-9"	32'-6"	29'-6"	27'-10"	23'-11"
		16"	33'-0"	30'-0"	28'-3"	25'-5"	36'-0"	32'-8"	30'-0"	23'-11"
-	PWI-77	9-1/2"	19'-8"	17'-11"	16'-11"	15'-9"	21'-5"	19'-6"	18'-4"	17'-1"
		11-7/8"	23'-4"	21'-4"	20'-1"	18'-9"	25'-5"	23'-2"	21'-10"	20'-4"
		14"	26'-6"	24'-2"	22'-10"	21'-3"	28'-11"	26'-4"	24'-10"	22'-0"
		16"	29'-4"	26'-9"	25'-3"	23'-6"	32'-0"	29'-2"	27'-6"	22'-0"
-	PWI-90	9-1/2"	22'-2"	20'-2"	19'-0"	17'-8"	24'-1"	21'-11"	20'-7"	19'-2"
		11-7/8"	26'-4"	23'-11"	22'-7"	21'-0"	28'-8"	26'-1"	24'-6"	22'-9"
		14"	29'-10"	27'-2"	25'-7"	23'-9"	32'-7"	29'-7"	27'-10"	25'-10"
		16"	33'-0"	30'-1"	28'-4"	26'-4"	36'-0"	32'-9"	30'-10"	26'-7"

For **SI** : 1 inch = 25.4 mm

1. Allowable simple or continuous clear spans applicable to residential floor construction with a design dead load of 10 psf and live load of 40 psf. Live load deflection is limited to L/480, where L is the span. Use beam sizing software to analyze continuous span joists if the length of any span is less than 40% of the length of an adjacent span.
2. Spans are based on a composite floor with glued and nailed sheathing meeting the requirements for APA Rated Sheathing or APA Rated STURD-I-FLOOR conforming to PRP-108, PS 1, or PS 2 with a minimum thickness of 19/32 inch (40/20 or 20 oc) for a joist spacing of 19.2 inches or less, or 23/32 inch (48/24 or 24 oc) for a joist spacing of 24 inches. Adhesive shall meet APA Specification AFG-01 or ASTM D 3498. Spans shall be reduced 12 inches when the floor sheathing is nailed only.
3. The minimum bearing length shall be 1-3/4 inches at end supports and 3-1/2 inches at intermediate supports.
4. Web stiffeners are not required at supports when the joists are used with the spans and spacings given in this table, except as may be required by hanger manufacturers.
5. PRI-400 Performance Standard for APA EWS I-Joists
6. Pacific Woodtech Corporation

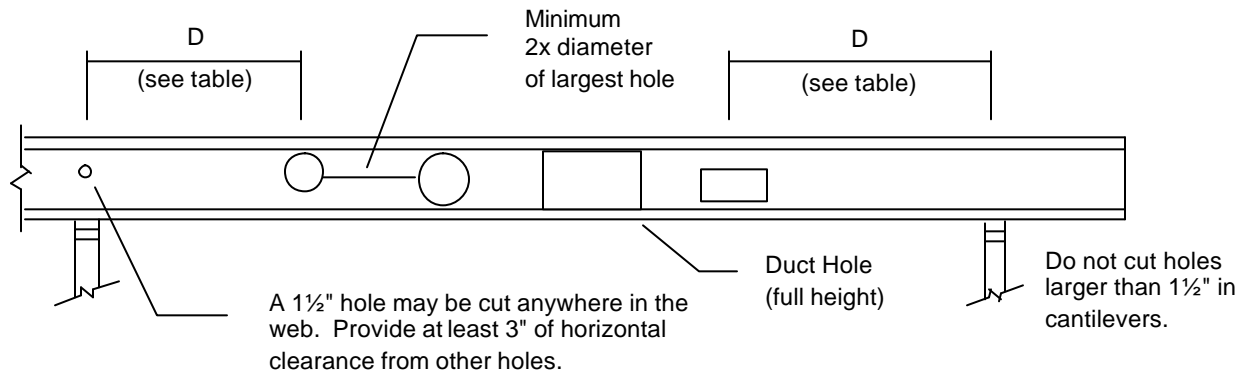

Table 4 – Duct Holes

Minimum Distance 'D' From Any Support to the Centerline of the Hole

Joist Series	Joist Span	Duct Hole Width				
		8"	10"	12"	14"	16"
20	8 ft.	3'-7"	3'-8"	3'-10"		
	12 ft.	5'-5"	5'-7"	5'-9"		
	16 ft.	7'-3"	7'-5"	7'-8"		
	20 ft.	9'-1"	9'-4"	9'-7"		
30	8 ft.	3'-9"	3'-10"	3'-11"		
	12 ft.	5'-8"	5'-9"	5'-11"		
	16 ft.	7'-6"	7'-8"	7'-11"		
	20 ft.	9'-5"	9'-8"	9'-10"		
40/60	8 ft.	3'-7"	3'-8"	3'-9"	3'-11"	
	12 ft.	5'-5"	5'-7"	5'-8"	5'-10"	
	16 ft.	7'-3"	7'-5"	7'-7"	7'-10"	
	20 ft.	9'-1"	9'-4"	9'-6"	9'-9"	
	24 ft.	10'-11"	11'-2"	11'-5"	11'-9"	
	28 ft.	12'-9"	13'-1"	13'-4"	13'-8"	
50	8 ft.	3'-8"	3'-9"	3'-10"	3'-11"	
	12 ft.	5'-6"	5'-7"	5'-9"	5'-11"	
	16 ft.	7'-4"	7'-6"	7'-9"	7'-11"	
	20 ft.	9'-2"	9'-5"	9'-8"	9'-11"	
	24 ft.	11'-0"	11'-3"	11'-7"	11'-11"	
	28 ft.	12'-10"	13'-2"	13'-7"	13'-11"	
70	12 ft.	5'-3"	5'-5"	5'-7"	5'-9"	5'-11"
	16 ft.	7'-1"	7'-3"	7'-5"	7'-8"	7'-10"
	20 ft.	8'-10"	9'-1"	9'-4"	9'-7"	9'-10"
	24 ft.	10'-7"	10'-11"	11'-2"	11'-6"	11'-10"
	28 ft.	12'-5"	12'-9"	13'-1"	13'-5"	13'-9"
	32 ft.	14'-2"	14'-7"	14'-11"	15'-4"	15'-9"
80/93	8 ft.	3'-7"	3'-8"	3'-9"	3'-10"	3'-11"
	12 ft.	5'-5"	5'-6"	5'-7"	5'-9"	5'-10"
	16 ft.	7'-2"	7'-4"	7'-6"	7'-8"	7'-10"
	20 ft.	9'-0"	9'-2"	9'-5"	9'-7"	9'-9"
	24 ft.	10'-10"	11'-0"	11'-3"	11'-6"	11'-9"
	28 ft.	12'-7"	12'-11"	13'-2"	13'-5"	13'-9"
77	12 ft.	5'-8"	5'-9"	5'-11"		
	16 ft.	7'-6"	7'-8"	7'-10"		
	20 ft.	9'-5"	9'-8"	9'-10"		
	24 ft.	11'-4"	11'-7"	11'-10"		
	28 ft.	13'-2"	13'-6"	13'-9"		
	32 ft.	15'-1"	15'-5"	15'-9"		
90 depth ≤ 20"	12 ft.	5'-7"	5'-8"	5'-10"	5'-11"	
	16 ft.	7'-6"	7'-7"	7'-9"	7'-11"	
	20 ft.	9'-4"	9'-6"	9'-8"	9'-10"	
	24 ft.	11'-3"	11'-5"	11'-8"	11'-10"	
	28 ft.	13'-1"	13'-4"	13'-7"	13'-10"	
	32 ft.	15'-0"	15'-3"	15'-6"	15'-10"	

Tables 4 & 5 Notes:

1. Table values apply to joists sized by means of Table 3 of this report
2. Web holes may be located anywhere between the joist flanges. Leave at least 1/8 inch clearance between the edges of holes and the flanges.
3. Do not cut holes in cantilevers.
4. The horizontal clearance between the edges of adjacent holes must be at least twice the diameter (or longest side) of the larger hole. Exception: A 1-1/2 inch diameter hole may be drilled anywhere in the web. Provide at least 3 inches of horizontal clearance from adjacent holes of any size.
5. 1-1/2 inch diameter holes are factory-scored in the web at 16 inches on center.

For Series 90 depths ≥ 22", refer to the engineered design recommendations in Section 2.2.3

For SI: 1 inch = 25.4 mm

Table 5 – Round and Rectangular Holes
 Minimum Distance 'D' From Any Support to the Centerline of the Hole – See Tables 4 & 5 Notes

Round Hole Diameter	2"	3"	4"	5"	6-1/4"	8-5/8"	10"	12-3/4"	14-3/4"	16-3/4"	
Rectangular Hole Side	1-1/2"	2-1/4"	3"	3-3/4"	4-1/2"	6-1/4"	7-1/2"	10"	12-3/4"	14-3/4"	16-3/4"
8 ft.	1'-0"	1'-6"	2'-1"	2'-7"	3'-3"	4'-11"	5'-4"	6'-8"	7'-4"	8'-0"	8'-6"
12 ft.	1'-6"	2'-4"	3'-1"	3'-11"	4'-11"	5'-11"	6'-8"	7'-11"	8'-6"	9'-2"	9'-8"
16 ft.	2'-1"	3'-1"	4'-2"	5'-3"	6'-6"	7'-11"	8'-6"	9'-11"	10'-6"	11'-2"	11'-8"
8 ft.	1'-0"	1'-1"	1'-7"	2'-0"	2'-6"	3'-7"	4'-2"	5'-0"	5'-6"	6'-0"	6'-6"
12 ft.	1'-0"	1'-8"	2'-4"	3'-0"	3'-10"	5'-4"	6'-9"	7'-4"	7'-10"	8'-4"	8'-10"
16 ft.	1'-5"	2'-3"	3'-2"	4'-0"	5'-1"	7'-2"	8'-5"	9'-2"	9'-8"	10'-2"	10'-8"
20 ft.	1'-9"	2'-10"	3'-11"	5'-0"	6'-4"	8'-11"	10'-1"	11'-0"	11'-6"	12'-0"	12'-6"
14" Joist (Span)	1'-0"	1'-1"	1'-5"	2'-0"	2'-9"	4'-2"	5'-0"	5'-6"	6'-0"	6'-6"	7'-0"
16" Joist (Span)	1'-0"	1'-1"	1'-10"	2'-8"	3'-8"	5'-7"	6'-9"	7'-4"	7'-10"	8'-4"	8'-10"
18" Joist (Span)	1'-0"	1'-4"	2'-4"	3'-4"	4'-7"	7'-0"	8'-5"	9'-2"	9'-8"	10'-2"	10'-8"
20" Joist (Span)	1'-0"	1'-7"	2'-10"	4'-0"	5'-7"	8'-5"	10'-1"	11'-0"	11'-6"	12'-0"	12'-6"
22" Joist (Span)	1'-0"	1'-1"	1'-2"	1'-2"	1'-6"	2'-11"	3'-9"	4'-3"	5'-0"	5'-6"	6'-0"
24" Joist (Span)	1'-0"	1'-1"	1'-2"	1'-2"	2'-0"	3'-11"	5'-1"	5'-8"	6'-8"	7'-4"	8'-0"
26" Joist (Span)	1'-0"	1'-1"	1'-2"	1'-3"	2'-6"	4'-11"	6'-4"	7'-1"	8'-5"	9'-2"	9'-8"
28" Joist (Span)	1'-0"	1'-1"	1'-2"	1'-6"	3'-0"	5'-11"	7'-7"	8'-6"	10'-1"	11'-0"	11'-6"
30" Joist (Span)	1'-0"	1'-1"	1'-2"	1'-9"	3'-7"	6'-11"	8'-11"	10'-0"	11'-9"	12'-10"	13'-11"
32" Joist (Span)	1'-0"	1'-1"	1'-2"	1'-2"	1'-3"	3'-7"	6'-11"	8'-11"	10'-0"	11'-9"	12'-10"
34" Joist (Span)	1'-0"	1'-1"	1'-2"	1'-2"	1'-3"	3'-7"	6'-11"	8'-11"	10'-0"	11'-9"	12'-10"
36" Joist (Span)	1'-0"	1'-1"	1'-2"	1'-2"	1'-3"	3'-7"	6'-11"	8'-11"	10'-0"	11'-9"	12'-10"
38" Joist (Span)	1'-0"	1'-1"	1'-2"	1'-2"	1'-3"	3'-7"	6'-11"	8'-11"	10'-0"	11'-9"	12'-10"
40" Joist (Span)	1'-0"	1'-1"	1'-2"	1'-2"	1'-3"	3'-7"	6'-11"	8'-11"	10'-0"	11'-9"	12'-10"
42" Joist (Span)	1'-0"	1'-1"	1'-2"	1'-2"	1'-3"	3'-7"	6'-11"	8'-11"	10'-0"	11'-9"	12'-10"
44" Joist (Span)	1'-0"	1'-1"	1'-2"	1'-2"	1'-3"	3'-7"	6'-11"	8'-11"	10'-0"	11'-9"	12'-10"
46" Joist (Span)	1'-0"	1'-1"	1'-2"	1'-2"	1'-3"	3'-7"	6'-11"	8'-11"	10'-0"	11'-9"	12'-10"
48" Joist (Span)	1'-0"	1'-1"	1'-2"	1'-2"	1'-3"	3'-7"	6'-11"	8'-11"	10'-0"	11'-9"	12'-10"
50" Joist (Span)	1'-0"	1'-1"	1'-2"	1'-2"	1'-3"	3'-7"	6'-11"	8'-11"	10'-0"	11'-9"	12'-10"
52" Joist (Span)	1'-0"	1'-1"	1'-2"	1'-2"	1'-3"	3'-7"	6'-11"	8'-11"	10'-0"	11'-9"	12'-10"
54" Joist (Span)	1'-0"	1'-1"	1'-2"	1'-2"	1'-3"	3'-7"	6'-11"	8'-11"	10'-0"	11'-9"	12'-10"
56" Joist (Span)	1'-0"	1'-1"	1'-2"	1'-2"	1'-3"	3'-7"	6'-11"	8'-11"	10'-0"	11'-9"	12'-10"
58" Joist (Span)	1'-0"	1'-1"	1'-2"	1'-2"	1'-3"	3'-7"	6'-11"	8'-11"	10'-0"	11'-9"	12'-10"
60" Joist (Span)	1'-0"	1'-1"	1'-2"	1'-2"	1'-3"	3'-7"	6'-11"	8'-11"	10'-0"	11'-9"	12'-10"
62" Joist (Span)	1'-0"	1'-1"	1'-2"	1'-2"	1'-3"	3'-7"	6'-11"	8'-11"	10'-0"	11'-9"	12'-10"
64" Joist (Span)	1'-0"	1'-1"	1'-2"	1'-2"	1'-3"	3'-7"	6'-11"	8'-11"	10'-0"	11'-9"	12'-10"
66" Joist (Span)	1'-0"	1'-1"	1'-2"	1'-2"	1'-3"	3'-7"	6'-11"	8'-11"	10'-0"	11'-9"	12'-10"
68" Joist (Span)	1'-0"	1'-1"	1'-2"	1'-2"	1'-3"	3'-7"	6'-11"	8'-11"	10'-0"	11'-9"	12'-10"
70" Joist (Span)	1'-0"	1'-1"	1'-2"	1'-2"	1'-3"	3'-7"	6'-11"	8'-11"	10'-0"	11'-9"	12'-10"
72" Joist (Span)	1'-0"	1'-1"	1'-2"	1'-2"	1'-3"	3'-7"	6'-11"	8'-11"	10'-0"	11'-9"	12'-10"
74" Joist (Span)	1'-0"	1'-1"	1'-2"	1'-2"	1'-3"	3'-7"	6'-11"	8'-11"	10'-0"	11'-9"	12'-10"
76" Joist (Span)	1'-0"	1'-1"	1'-2"	1'-2"	1'-3"	3'-7"	6'-11"	8'-11"	10'-0"	11'-9"	12'-10"
78" Joist (Span)	1'-0"	1'-1"	1'-2"	1'-2"	1'-3"	3'-7"	6'-11"	8'-11"	10'-0"	11'-9"	12'-10"
80" Joist (Span)	1'-0"	1'-1"	1'-2"	1'-2"	1'-3"	3'-7"	6'-11"	8'-11"	10'-0"	11'-9"	12'-10"
82" Joist (Span)	1'-0"	1'-1"	1'-2"	1'-2"	1'-3"	3'-7"	6'-11"	8'-11"	10'-0"	11'-9"	12'-10"
84" Joist (Span)	1'-0"	1'-1"	1'-2"	1'-2"	1'-3"	3'-7"	6'-11"	8'-11"	10'-0"	11'-9"	12'-10"
86" Joist (Span)	1'-0"	1'-1"	1'-2"	1'-2"	1'-3"	3'-7"	6'-11"	8'-11"	10'-0"	11'-9"	12'-10"
88" Joist (Span)	1'-0"	1'-1"	1'-2"	1'-2"	1'-3"	3'-7"	6'-11"	8'-11"	10'-0"	11'-9"	12'-10"
90" Joist (Span)	1'-0"	1'-1"	1'-2"	1'-2"	1'-3"	3'-7"	6'-11"	8'-11"	10'-0"	11'-9"	12'-10"
92" Joist (Span)	1'-0"	1'-1"	1'-2"	1'-2"	1'-3"	3'-7"	6'-11"	8'-11"	10'-0"	11'-9"	12'-10"
94" Joist (Span)	1'-0"	1'-1"	1'-2"	1'-2"	1'-3"	3'-7"	6'-11"	8'-11"	10'-0"	11'-9"	12'-10"
96" Joist (Span)	1'-0"	1'-1"	1'-2"	1'-2"	1'-3"	3'-7"	6'-11"	8'-11"	10'-0"	11'-9"	12'-10"
98" Joist (Span)	1'-0"	1'-1"	1'-2"	1'-2"	1'-3"	3'-7"	6'-11"	8'-11"	10'-0"	11'-9"	12'-10"
100" Joist (Span)	1'-0"	1'-1"	1'-2"	1'-2"	1'-3"	3'-7"	6'-11"	8'-11"	10'-0"	11'-9"	12'-10"